

# Captiva Island 2014



**real flame**  
Leaders in  
Gas Fireplace  
Technology

## Be captivated from all angles

The Captiva Island is available in a two or three sided configuration allowing the home owner to view the fire from two separate rooms, or from three sides in a large open plan area.

This double glazed high efficiency fire has a large heating capacity and uses direct vent balanced flue technology allowing horizontal or vertical termination of the flue.

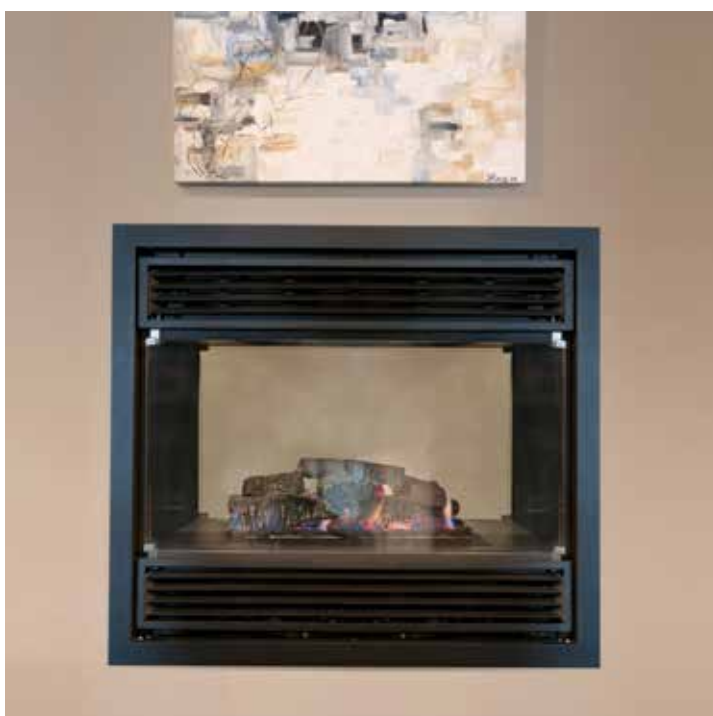

# Captiva Island

2 Sided

3 Sided

- 🔥 Conceived, designed, researched, developed and built in Australia
- 🔥 Double glazed space heater
- 🔥 New application
- 🔥 Heats up to 130m<sup>2</sup>
- 🔥 Contemporary
- 🔥 Balanced flue
- 🔥 Full remote control function
- 🔥 Pebbles or Coals and logs
- 🔥 Natural gas or LPG



# SPECIFICATIONS & CONSTRUCTION

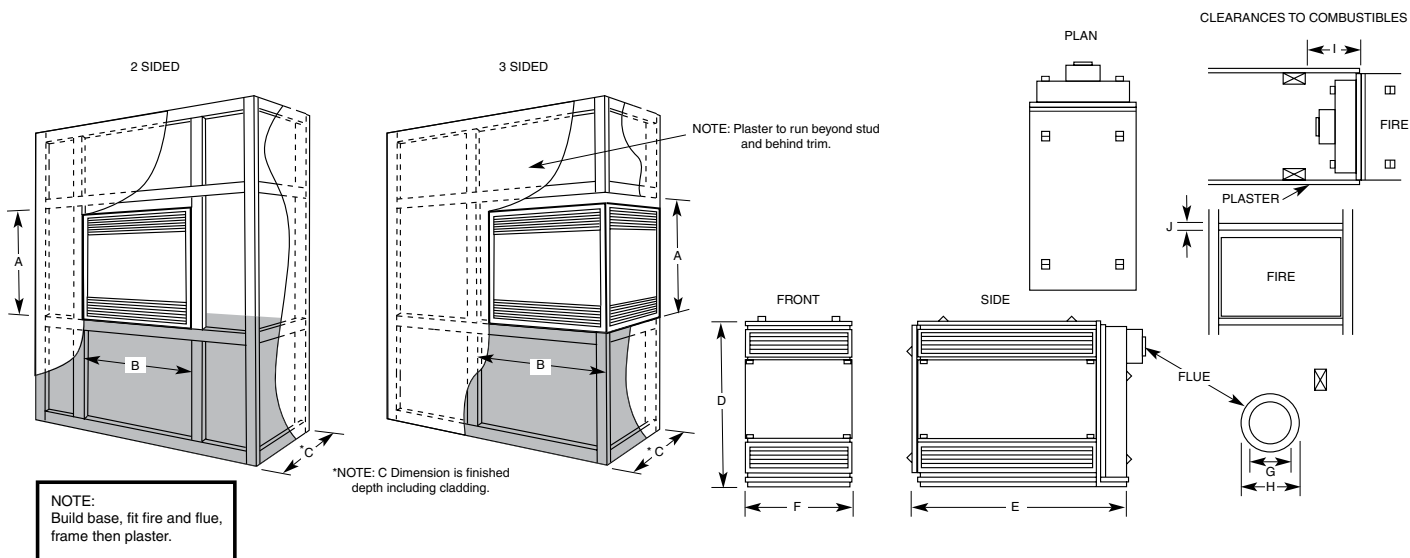

	A	B	C*	D	E	F	G	H	I	J	NG Mj/H	LP Mj/H	KW Output	STAR RATING FROM	STAR RATING TO	GPO REQ'D	VENTILATION
<b>2 SIDED</b>	1000	1225	560	870	1100	560	100	180	50	100	43	43	9	2.8	4.5	YES	NOT REQUIRED
<b>3 SIDED</b>	1000	1150	560	870	1100	560	100	180	50	100	43	43	9	2.8	4.5	YES	NOT REQUIRED

Refer to trim section for dimensions of 2 or 3 sided models

Warranty: Provided your Real Flame Gas Fire is installed by a licensed Gas Fitter in accordance with our Installation Instructions and operated in accordance with our Operating Manual, your Firebox is warranted for ten years and all other parts for one year from date of purchase. Refer to our website or our Installation and Operating Manual for a comprehensive warranty.

## Head Office/Factory/ Showroom

1340 Ferntree Gully Road  
Scoresby VIC 3179  
T 03 8706 2000

## Showrooms

300 Swan St, Richmond, VIC  
T 03 9428 4443

2a Gordon Ave, Geelong West, VIC  
T 03 5229 0844

9 Lonsdale St, Dandenong, VIC  
T 03 9702 4707

546 Pacific Hwy, Chatswood, NSW  
T 02 8905 0189

36 Kareena Rd, Miranda, NSW  
T 02 8513 6202

173-175 Magill Rd, Norwood, SA  
T 08 8132 0371

46 Douglas St, Milton, QLD  
T 07 3368 2011

47-53 McDonald St East, Osborne Park, WA  
T 08 9444 9900

88 Wollongong St, Fyshwick, ACT  
T 02 6280 552

## Available from

